

# SHIPCO<sup>®</sup> PUMPS

SHIPPENSBURG PUMP CO., INC.  
P.O. BOX 279, SHIPPENSBURG, PA 17257  
PHONE 717-532-7321 • FAX 717-532-7704  
WWW.SHIPCOPUMPS.COM

PRIDE

QUALITY

CRAFTSMANSHIP

**BULLETIN 111**  
*Revised 9/11*

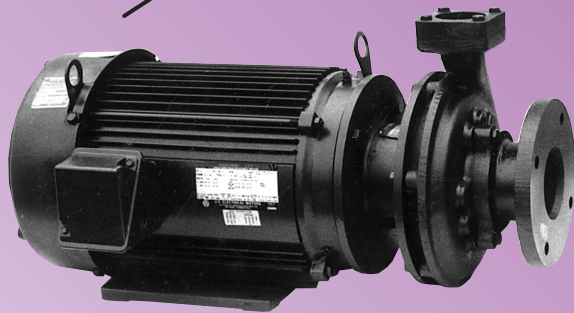

**DH**  
(Horizontal Flange Mounted)

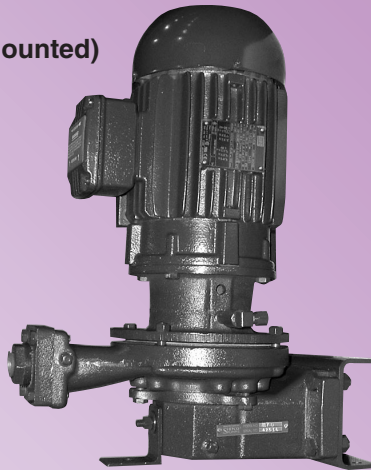

**DFT**  
(For Threaded  
Suction Application)

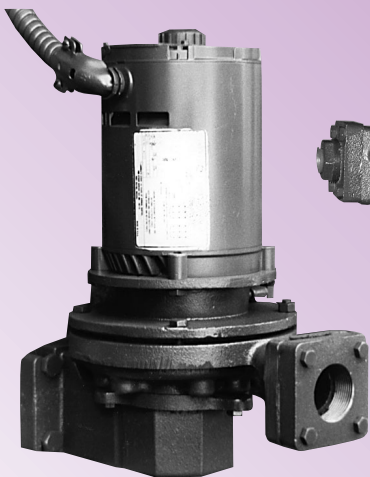

**DF**  
(Vertical Flange Mounted)

## MODEL D

Cast Iron  
Bronze Fitted  
Centrifugal Pumps

**SHIPCO<sup>®</sup>**  
**SPUMPS** are equipped with Mechanical Seals rated for  
temperatures up to 250°F as standard.  
Higher temperature seals and special faces available upon request.

Pump Discharge may be rotated 90° in either direction from position shown (except Models 110 & 106)

## Model D - 56J Frame

- |                           |  |
|---------------------------|--|
| 1. Pump Head              | 12. Wear Ring                              |
| 2. Pump Case              | 13. Suction Housing                        |
| 3. Motor                  | 14. Capscrews<br>(Suction Housing to Case) |
| 4. Motor Shaft            | 15. Suction Housing Gasket                 |
| 5. Water Slinger          | 16. Drip Cover                             |
| 6. Impeller               | 17. Impeller Locking Nut                   |
| 7. Mechanical Seal        | 18. Capscrews                              |
| 8. Pump Suction Gasket    | 19. Capscrews                              |
| 9. Discharge Flange       | 20. Capscrews                              |
| 10. Pump Discharge Gasket |  |
| 11. Head Gasket           |  |

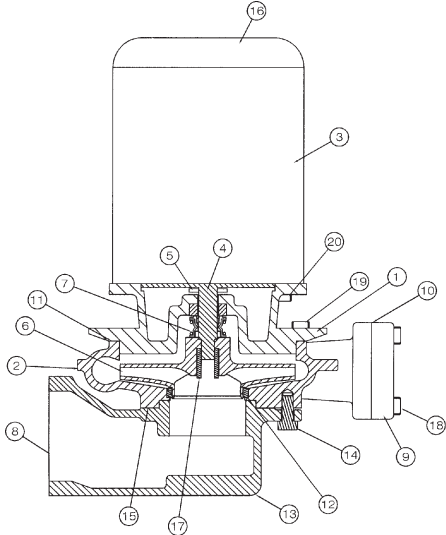

## Model D - JM Frame

- |                           |  |
|---------------------------|--|
| 1. Pump Head              | 13. Suction Housing                        |
| 2. Pump Case              | 14. Capscrews<br>(Suction Housing to Case) |
| 3. Motor                  | 15. Suction Housing Gasket                 |
| 4. Motor Shaft            | 16. Impeller Screw                         |
| 5. Water Slinger          | 17. Drip Cover                             |
| 6. Impeller               | 18. Capscrews                              |
| 7. Mechanical Seal        | 19. Capscrews                              |
| 8. Pump Suction Gasket    | 20. Capscrews                              |
| 9. Discharge Flange       | 21. Impeller Washer                        |
| 10. Pump Discharge Gasket | 22. Shaft Sleeve (Mech. Seal)              |
| 11. Head Gasket           |  |
| 12. Wear Ring             |  |

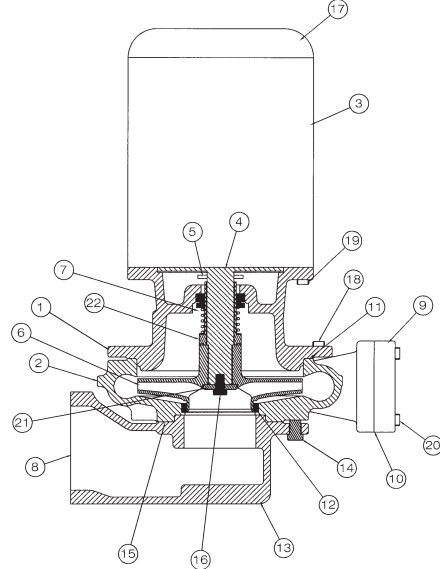

### Approximate Model D 3500 RPM Pump Ranges

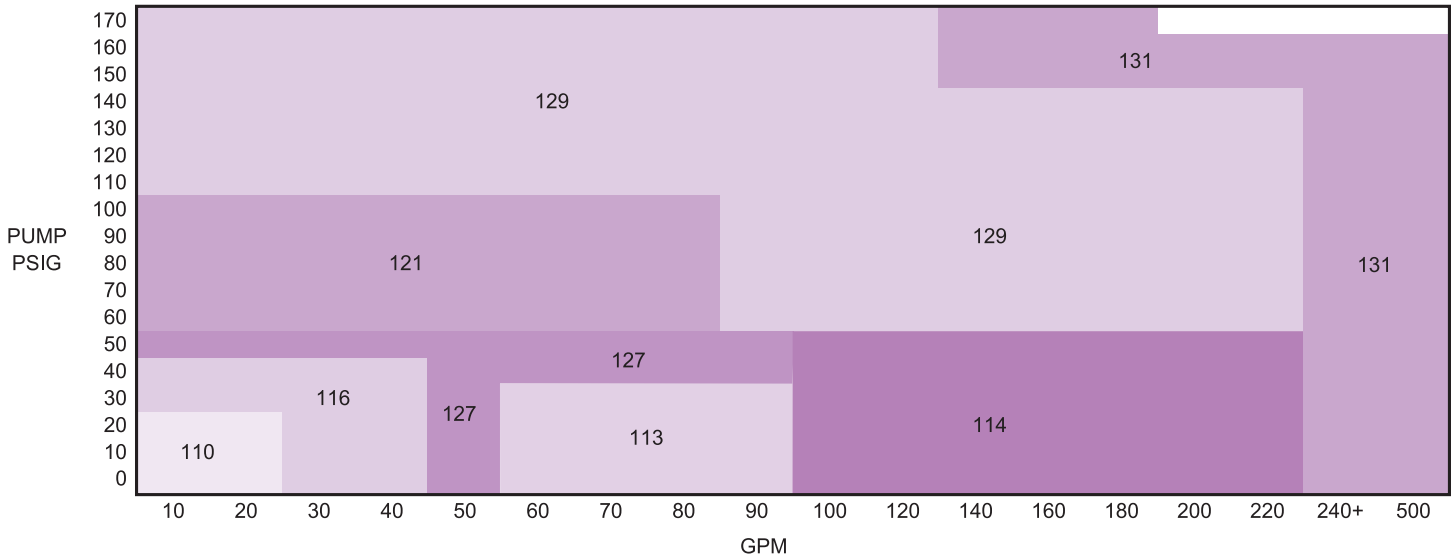

### Approximate Model D 1750 RPM Pump Ranges

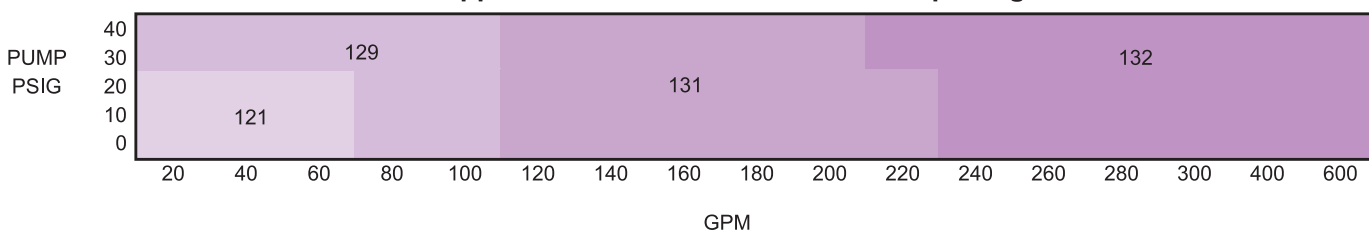

## Centrifugal Pump

A single-stage, centrifugal, bronze-fitted design for applications with temperatures typically 200°F or less. However, higher temperatures are possible depending on specific operating conditions. Pump types (such as 106-D, 110-D, etc.) selected depends on the design operating conditions—flow rate, discharge pressure and NPSH requirements; impellers trimmed to operating conditions. Can be flange-mounted either vertically (DF) or horizontally (DH). Vertical mounting saves floor space and avoids dirt and water. Pump can also be fitted with a threaded suction adapter flange for in-line applications (DFT).

Equipped with industry standard motors available in single or three-phase at either 1750 RPM or 3500 RPM. Pumps are furnished with bleed lines, sometimes called seal flushing lines, to help prevent the pump from vapor binding and to allow pump operation against a dead shut-off for a period of time without burning seals. Standard mechanical seals provide for temperatures up to 250°F. Higher temperature seals and special faces available upon request.

An optional isolation valve for installation in the suction piping is available on DF style pump to quickly remove the pump for repair and maintenance without draining the receiver and saving labor costs.

## Isolation Valve

### ***Factory Tested for Leaks Mounted between Pump and Receiver Tank***

#### *Efficiency*

- Eliminate wasting large amounts of condensate
- Save time and money on maintenance

#### *High Quality Construction*

- All bronze construction
- "O" Ring in housing allows for thermal expansion

#### *Adaptability*

- Can be adapted to pumps of most major manufacturers
- Used only on vented atmospheric units

#### *Easy to Use*

- Replacement of pump seals made easy
- Stop pins to ensure closure
- Flow indicated by handle direction

#### *Safety*

- For lock out/tag out, a blind flange/gasket must be installed after valve

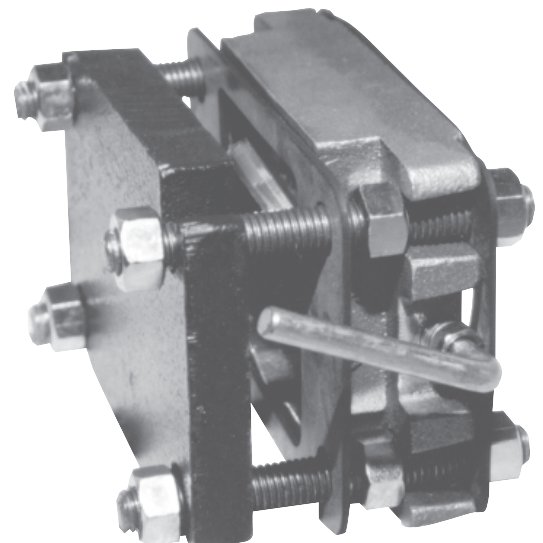
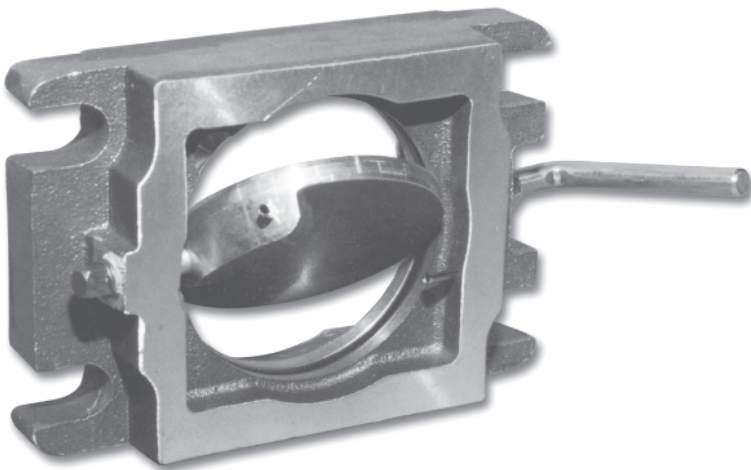

## Suction Piping – Elevated Units Only

If pump is not bolted onto the side of a floor-mounted unit (elevated tank above pump), always install a section of straight pipe (18" minimum) between the suction of the pump and first elbow.

The recommended suction piping size is shown below:

	Max. GPM 210°F or Less	Max. GPM Greater than 210°F
2"	52	30
2-1/2"	75	43
3"	114	66
4"	200	116
5"	312	181
6"	450	261
8"	750	450

If tank suction pipe size is larger or smaller than pump suction connection, a reducing elbow is required.

Be sure to eliminate any pipe strain on the pump. Support the suction and discharge pipes independently by using pipe hangers near the pump. Line up the vertical and horizontal piping so that the bolt holes in the pump flanges match the bolt holes in the pipe flanges. Do not attempt to spring the suction or discharge lines into position. The code for pressure piping (ASME Section 1) must be followed as well as any local codes.

Where considerable temperature changes or seismic zone areas are anticipated, fittings for absorbing expansion should be installed in the system in a way to avoid strain on the pump.

Pump suction strainers are NOT to be placed ahead of a centrifugal pump in the suction piping. NPSHA can not be calculated. Strainers will shut off water supply or cause a restriction. This will result in pump and mechanical seal failures. All strainers belong in return lines back to receiver tanks and also in make-up water lines.

Suction strainers are never used with SHIPCO® centrifugal pumps. Strainers are placed in the inlets to the tanks and not in the suction piping. No one can predict the pressure drop through a strainer and once it gets clogged your pump will run dry and destroy itself. Besides, centrifugal pumps can handle some dirt and debris. If you are using turbine pumps it is the lesser of two evils. Turbines have close tolerances and a little dirt will destroy the pump; therefore, suction strainers are used even though they will clog and destroy the motor if they are not kept clean.

## Discharge Piping

Install a union immediately beyond the pump discharge. A spring-loaded check valve should be installed in the discharge piping close to the pump to prevent backflow into the unit. A throttling valve (ball valve, globe valve or steam cock) must be installed after the check valve close to the pump. If pump is rated for 75 PSIG or greater the pump comes equipped with an automatic flow control valve that serves as the throttling valve. The throttling valve or automatic valve is used to set pump discharge at design conditions to prevent motor overload and cavitation. (See figure 2.1, 2.2).

## Notes on Piping

1. When installing the pump, suction and discharge gauge ports should be installed in the pipeline.
2. The piping should have isolation valves around the pump and have a drain valve in the suction line.
3. When installing the suction and discharge connections to a threaded pump housing a Teflon tape sealer or a high quality thread sealant is recommended.

## Boiler Feed Sizing

Selection is based on GPM, receiver size, and PSIG.

## Determine GPM

The evaporation rate of one boiler horsepower is .069 gallons per minute. Boiler feed pumps are sized at a rate of 1.5 to 2 times this evaporation rate. Boilers are usually rated in boiler horsepower. However, some may be rated in sq. ft. EDR or lbs/hr.

(Conversion Equivalents): One boiler horsepower equals .069 GPM or 33,475 BTU or 34.5 lbs/hr or 139.4 sq. ft. EDR.

## Determine PSIG

Generally low pressure boilers run at .5 to 15 PSIG. Therefore, a discharge pump pressure of 20 PSIG should be adequate. Boiler feed units are usually near the boilers they feed. To be safe you should determine the amount of vertical rise + friction loss in pipe + valve loss + feed valve loss (if any) + back pressure in line (boiler operating pressure) + a safety margin of approximately 5 PSIG. The amount of these values, or these values added together, are normally expressed in feet of head. To convert to pounds per square inch or PSIG, 2.31 feet of head = 1 PSIG.

# TYPICAL PIPING DIAGRAM

FIGURE 2

NOTE: The seal flushing (bleed) line must be field installed as detailed in Figure 2 when pumps are field piped. Factory packages include flushing line.

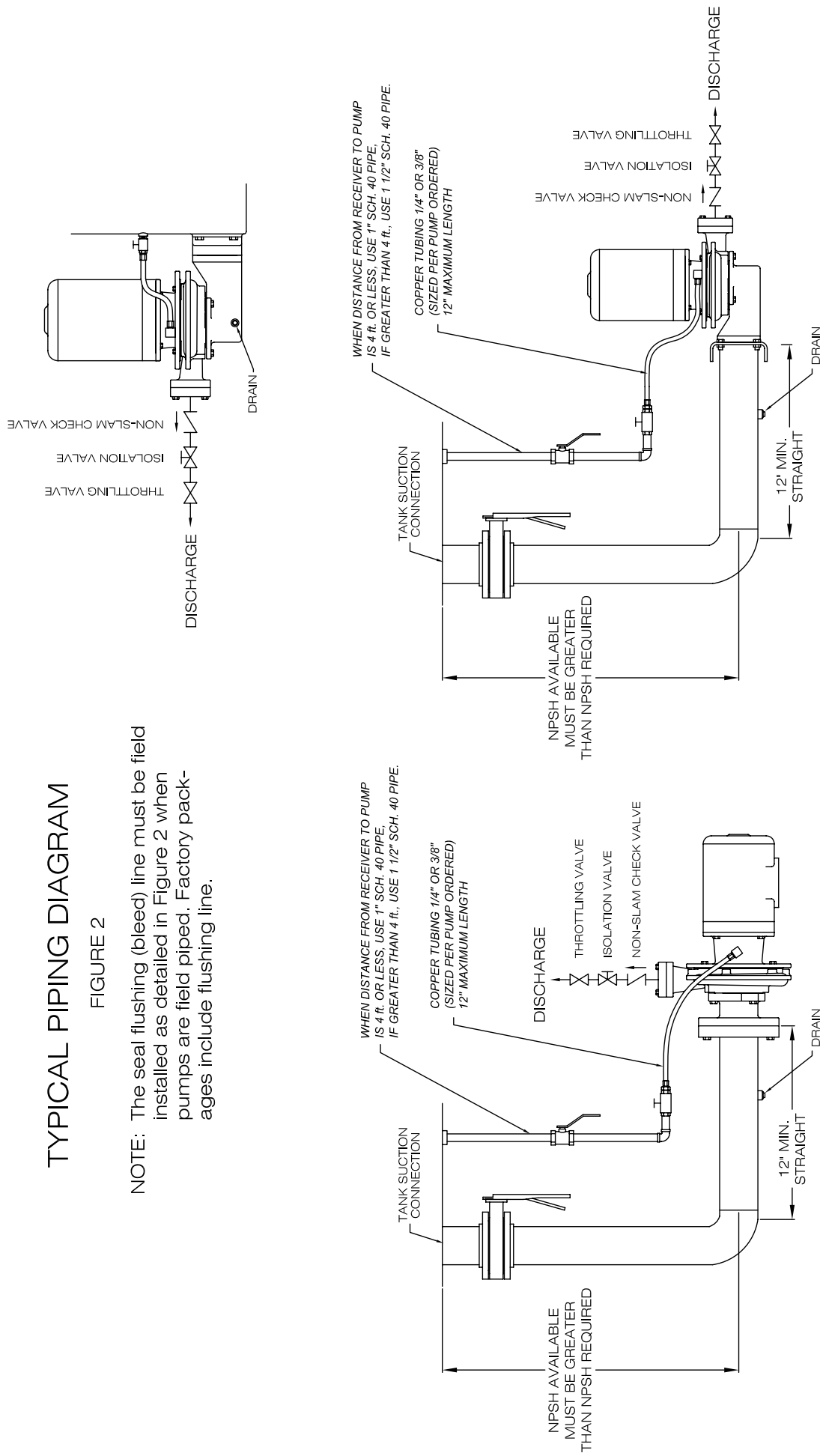

All intellectual property rights (including, without limitation, all copyright and design rights) expressed in the drawings and related information belongs to Shippensburg Pump Company, Inc. The User may not, under any circumstances use or allow the use of drawings with any product or system other than Shippensburg Pump Company, Inc. products or systems. This product must be installed and used in such a manner that standard operating pressures are not exceeded. This product may not be changed, altered, installed, used, or operated in any manner other than as manufactured and specified by Shippensburg Pump Company, Inc. The installation procedures and instructions as described in the product IOM Manual must be strictly followed. Any change or alteration in this product, or any deviations from the installation instructions, will void the product warranty. In addition, Shippensburg Pump Company, Inc. will not be responsible for any damages or injuries that occur to persons or property if the product is changed, altered, installed, used, or if operating pressures are increased, in any manner not consistent with and as set forth in printed materials supplied with this product by Shippensburg Pump Company, Inc. All Shippensburg Pump Company, Inc. drawings are subject to the published Terms & Conditions of Use of Drawings as expressed on Shippensburg Pump Company, Inc.'s website, [www.shipcopumps.com](http://www.shipcopumps.com), and in its catalog. Copies supplied upon request to our sales office at (717) 532-7321.

# TYPICAL PIPING DIAGRAM W/ AUTOMATIC FLOW VALVE

FIGURE 2.1

NOTE: The seal flushing (bleed) line must be field installed as detailed in Figure 2.1 when pumps are field piped. Factory packages include flushing line.

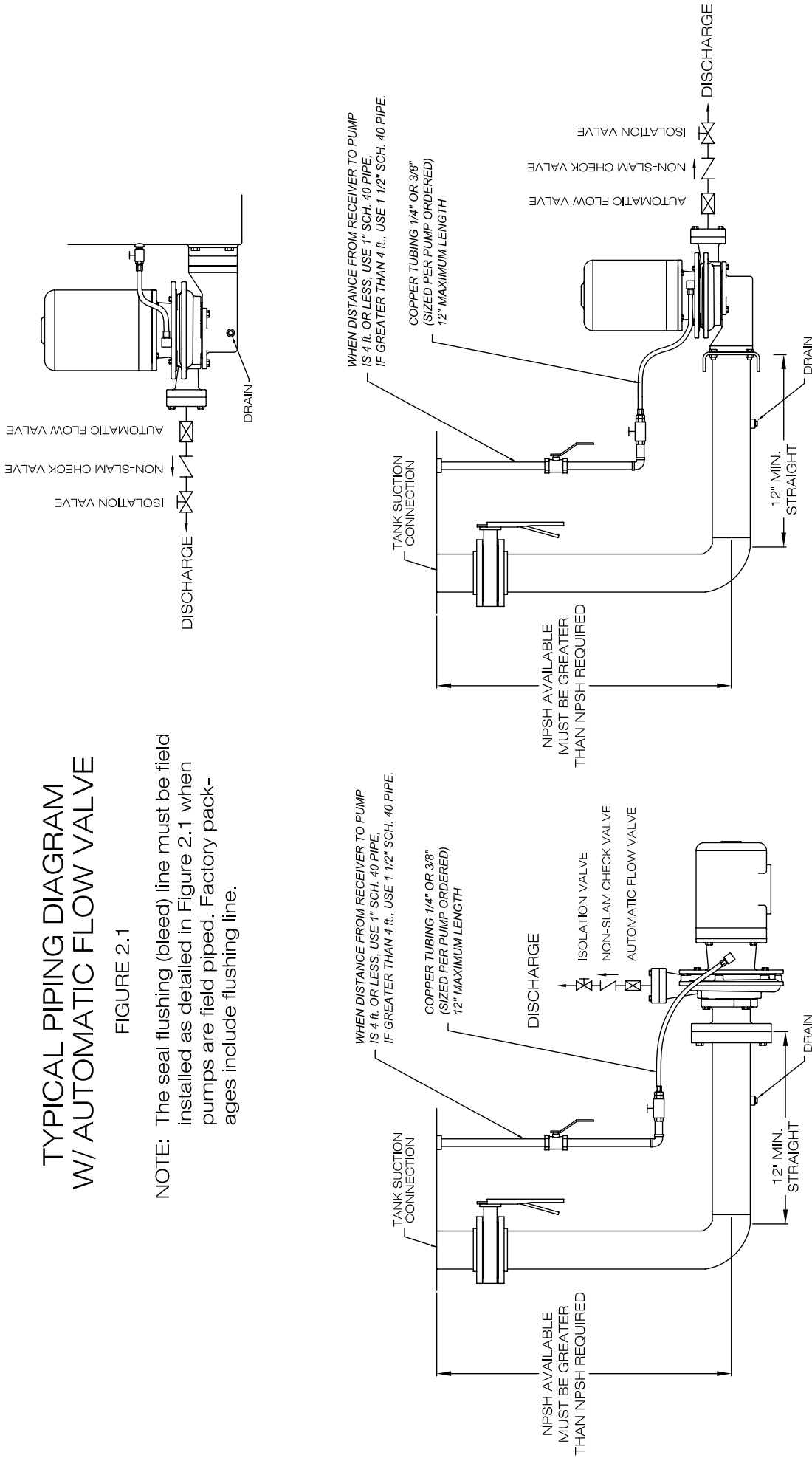

All intellectual property rights (including, without limitation, all copyright and design rights) expressed in the drawings and related information belongs to Shippensburg Pump Company, Inc. The User may not, under any circumstances use or allow the use of drawings with any product or system other than Shippensburg Pump Company, Inc. products or systems. This product must be installed and used in such a manner that standard operating pressures are not exceeded. This product may not be changed, altered, installed, used, or operated in any manner other than as manufactured and specified by Shippensburg Pump Company, Inc. The installation procedures and instructions as described in the product IOM Manual must be strictly followed. Any change or alteration in this product, or any deviation from the installation instructions, will void the product warranty. In addition, Shippensburg Pump Company, Inc. will not be responsible for any damages or injuries that occur to persons or property if the product is changed, altered, used, or if operating pressures are increased, in any manner not consistent with and as set forth in printed materials supplied with this product by Shippensburg Pump Company, Inc. All Shippensburg Pump Company, Inc. drawings are subject to the published Terms & Conditions of Use of Drawings as expressed on Shippensburg Pump Company, Inc.'s website, [www.shippcopumps.com](http://www.shippcopumps.com), and in its catalog. Copies supplied upon request to our sales office at (717) 532-7321.

**FOR DEAERATOR APPLICATIONS ONLY**  
 (WHEN MOTOR HORSEPOWER IS 7 1/2 HP & LARGER)  
**TYPICAL PIPING DIAGRAM**  
**CONTINUOUS RUN W/ ORIFICE BYPASS**  
**& AUTOMATIC FLOW VALVE**

FIGURE 2.2

NOTE: The seal flushing (bleed) line must be field installed as detailed in Figure 2.2 when pumps are field piped. Factory packages include flushing line.

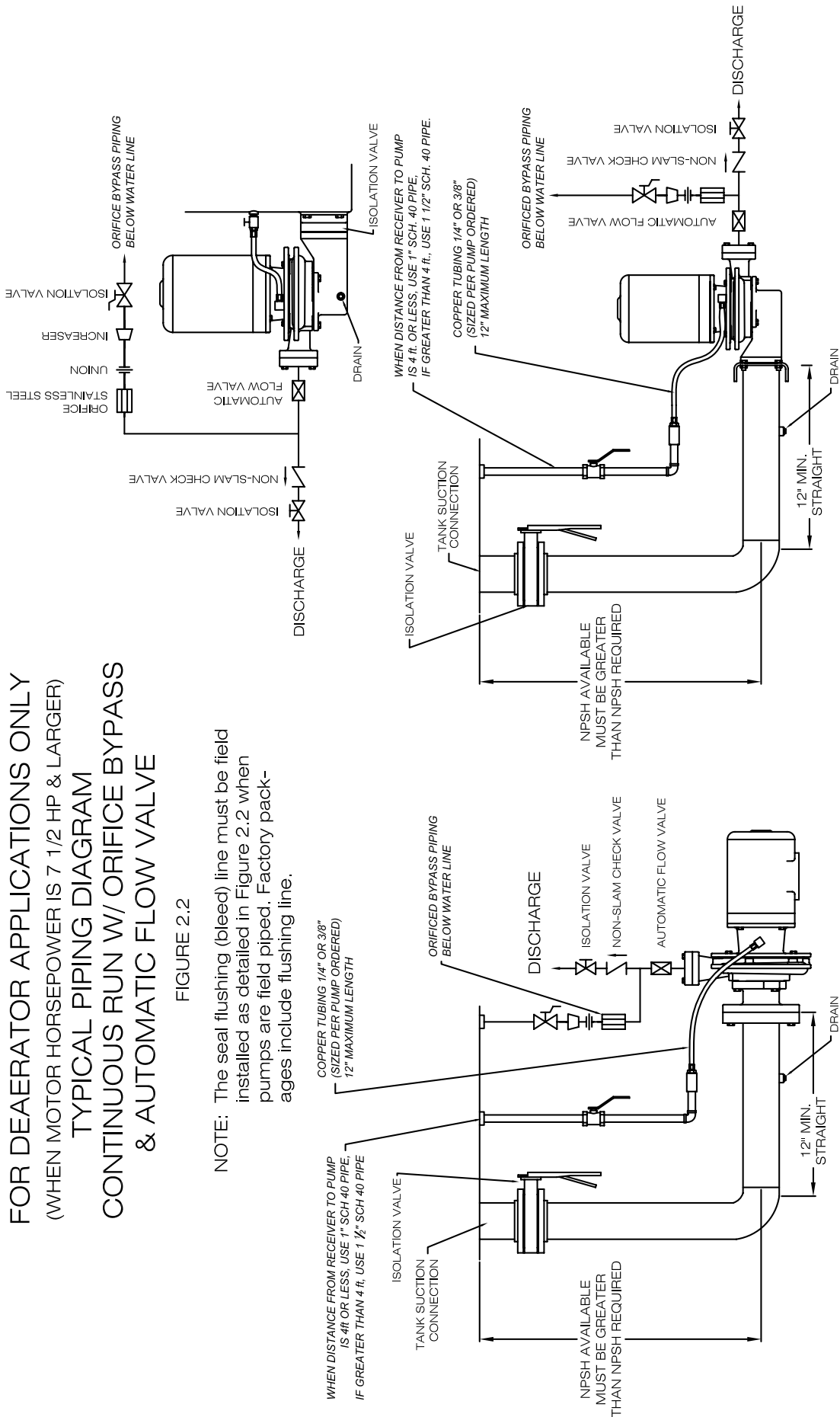

All intellectual property rights (including, without limitation, all copyright and design rights) expressed in the drawings and related information belongs to Shippensburg Pump Company, Inc. The User may not, under any circumstances use or allow the use of drawings with any product or system other than Shippensburg Pump Company, Inc. products or systems. This product must be installed and used in such a manner that standard operating pressures are not exceeded. This product may not be changed, altered, installed, used, or operated in any manner other than as manufactured and specified by Shippensburg Pump Company, Inc. The installation procedures and instructions as described in the product IOM Manual must be strictly followed. Any change or alteration in this product, or any deviation from the installation instructions, will void the product warranty. In addition, Shippensburg Pump Company, Inc. will not be responsible for any damages or injuries that occur to persons or property if the product is changed, altered, used, or if operating pressures are increased, in any manner not consistent with and as set forth in printed materials supplied with this product by Shippensburg Pump Company, Inc. All Shippensburg Pump Company, Inc. drawings are subject to the published Terms & Conditions of Use of Drawings as expressed on Shippensburg Pump Company, Inc.'s website, [www.shippcopumps.com](http://www.shippcopumps.com), and in its catalog. Copies supplied upon request to our sales office at (717) 532-7321.

**SHIPCO® has an adapter flange to retrofit our pump with an Industry Standard DF pump and motor to your existing unit!  
If your model isn't listed below we will make one.**

**AURORA**

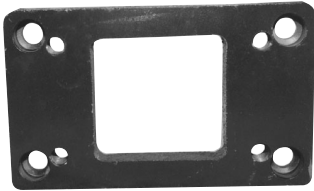

**SDPF00249**  
6 1/4" x 3 1/4" BOLT PATTERN

**MEPCO (Formerly Dunham-Bush)**

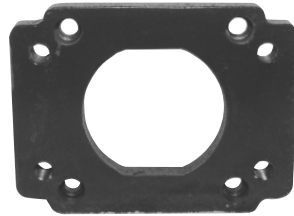

**SDPF00159**  
3 1/4" x 3 1/4" BOLT PATTERN  
(1) cover plate w/1 gasket included  
**\*SDPF00159-CA**  
Custom adapter flange for use with a **Mepco** (formerly **Dunham-Bush**) pump when using a **SHIPCO®** isolation valve

**ECONOMY**

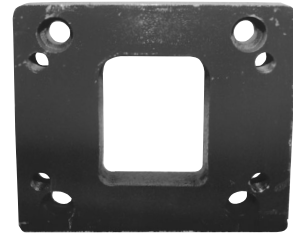

**SDPF00182**  
4 1/4" x 4" BOLT PATTERN  
**\*SDPF00182-CA**  
Custom adapter flange for use with an **ECONOMY** pump when using a **SHIPCO®** isolation valve

**FEDERAL**

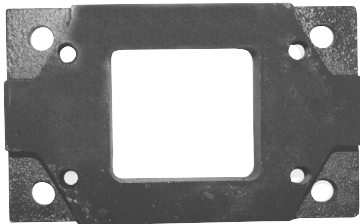

**SDPF00168**  
6 1/4" x 3 1/2" BOLT PATTERN

**STERLING**

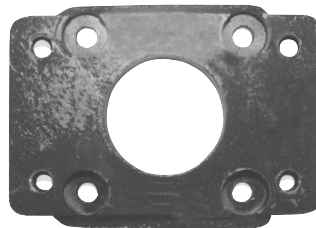

**SDPF00167**  
3 3/4" x 3 3/4" BOLT PATTERN

**HOFFMAN**

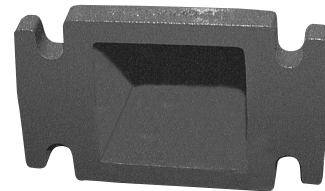

**ITT Domestic® ITT Hoffman® Pumps**  
up to 130 GPM flow rate  
do NOT require an adapter flange  
2 3/4" x 5" BOLT PATTERN  
ITT Domestic & ITT Hoffman are Trademarks of ITT Corporation

**SKIDMORE**



**SDPF00245-B**  
4 1/4" x 4 1/4" BOLT PATTERN  
**\*SDPF00245-CA**  
Custom adapter flange for use with a **SKIDMORE** pump mounted when used on an existing steel receiver or when used with a **SHIPCO®** isolation valve

**NASH**



**SDPF00034**  
9 1/8" Diameter BOLT PATTERN

**WEINMAN**

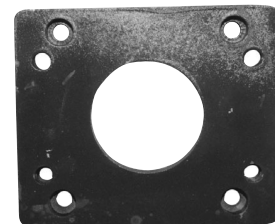

**SDPF00210**  
4 1/8" x 4 1/8" BOLT PATTERN  
**\*SDPF00210-CA**  
Custom adapter flange for use with a **WEINMAN** pump when using a **SHIPCO®** isolation valve

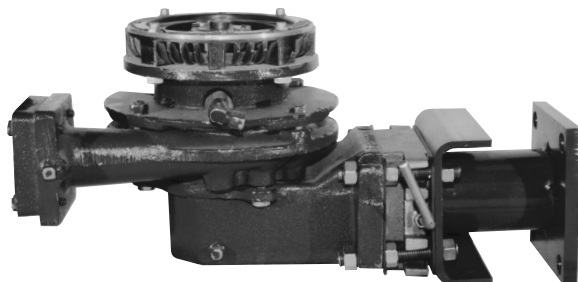

**\*PUMP WITH SHIPCO® BUTTERFLY FLANGE MOUNTED ISOLATION VALVE & CUSTOM ADAPTER FLANGE**

*\*Custom Adapter Flanges Available Upon Request*

*Just provide the existing bolt pattern and hole size required*

**SHIPCO® utilizes industry standard motors.**