

SERIES 35-60, 35-61



35.60/61.A

Installation Instructions 24 VAC Microprocessor Based DSI Control

DESCRIPTION

The Series 35-60 and 35-61 are Direct Spark Ignition Controls designed for use in all types of heating applications. They utilize a microprocessor to continually and safely analyze and control the proper operation of the gas burner. Value added features such as LED diagnostics, automatic one hour reset, and flame current test pins highlight the controls benefits.

SPECIFICATIONS

| | |
|---|--|
| Input Power Voltage | Control: 18 to 30 VAC 50/60 Hz (Class 2 Transformer) Line: 120 or 240 VAC (L1 & IND contacts only) |
| Current | 300 mA max @ 24 VAC with blower and gas valve relay energized (Control only) |
| Output (Contact Ratings) Gas Valve | 2.0A max @ 24 VAC |
| Combustion Blower (Model 35-61 only) | 3.0 FLA @ 120 VAC (6.0 LRA) 1.5 FLA @ 240 VAC (3.0 LRA) 1/4 H.P. Motor |
| Operating Temperature | -40°F to +176°F (-40°C to +80°C) |
| Flame Sensitivity | 0.7µA minimum |
| Flame Failure Response Time | 0.8 seconds maximum |
| Types of Gas | Natural, LP, or manufactured |
| Spark Rate | Line frequency (50/60 sparks/ sec.) |
| Size (LxWXH) | 5.684" x 3.934" x 1.875" (with cover) 5.281" x 3.718" x 2.080" (edge connect) |
| Enclosure | Gray (Noryl N-190) fire retardant plastic |
| Moisture Resistance | Conformal coated to operate non-condensing to 95% R.H. Care must be taken to protect module from direct exposure to water |
| Weight | 8 oz including cover |
| Tries for ignition | One or three try versions available |
| Trial for ignition Periods | 4.0, 7.0, 10.0, or 15.0 seconds standard Contact factory for other settings |
| Prepurge & Interpurge | None, 15, or 30 seconds depending on model. Without prepurge there is a one second delay before the first try for ignition |
| Edge Connect Version | Optional Edge connect model for replacement product |

CAUTION: Operation outside specifications could result in failure of the Fenwal product and other equipment with injury to people

CAUTION: Label all wires prior to disconnection when servicing controls. Wiring errors can cause improper and dangerous operation.

| TERMINAL DESIGNATIONS - QUICK CONNECT MODELS | | |
|--|---------------------------------|---|
| 24VAC/R | 24 VAC Supply to Processor | 1/4" Quick Connect |
| TH/W | Thermostat Input | 1/4" Quick Connect |
| PSW | Pressure Switch Input | 1/4" Quick Connect |
| GND | System Ground | 1/4" Quick Connect on 35-60 3/16" Quick Connect on 35-61 |
| V1 | Valve Power (output) | 3/16" Quick Connect |
| V2 | Valve Ground | 3/16" Quick Connect |
| L1 | 120/240 VAC Input (hot) | 1/4" Quick Connect |
| IND | Inducer Blower (output) | 1/4" Quick Connect |
| NC | Alarm (normally closed contact) | 1/4" Quick Connect |
| S1 | Remote Flame Sensor | 3/16" Quick Connect |
| FC+, FC- | Flame Current Test Pins | |

WIRING DIAGRAMS

Series 35-60

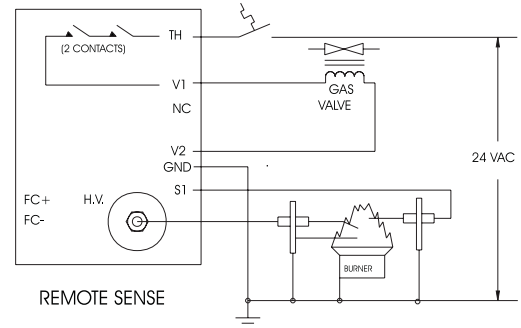
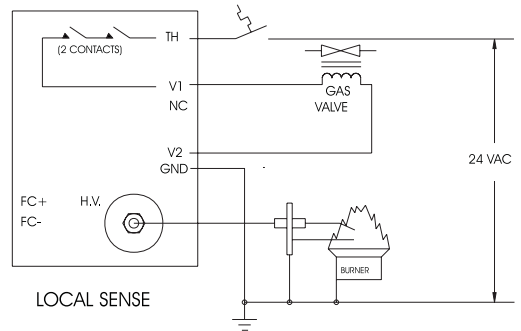

Series 35-61

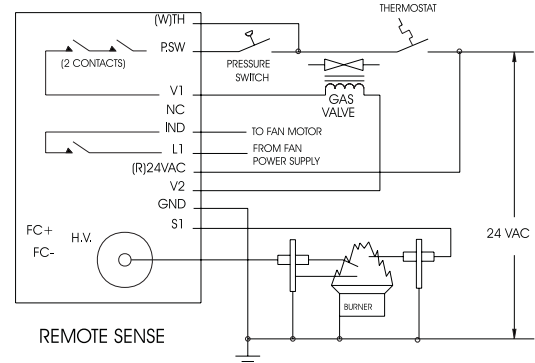
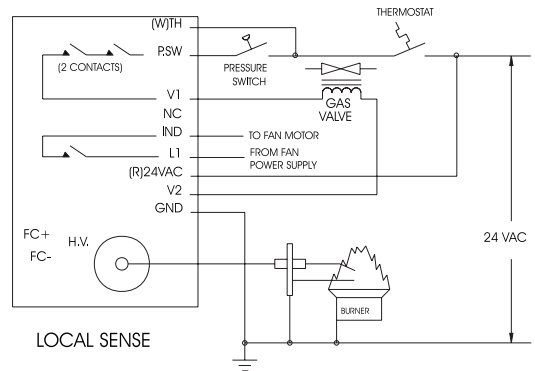

Mounting and Wiring

The Series 35-60 and 35-61 are not position sensitive and can be mounted vertically or horizontally. The case may be mounted on any surface with #6 sheet metal screws. The controls must be secured in an area that will experience minimum vibration and remain below the maximum operating temperature of 176°F. All connections should be made with UL approved 105°C rated 18 gauge, stranded, .054 thick insulated wire. Refer to wiring diagram when connecting the Series 35-60 or 35-61 to other components in the system.

WARNING: All wiring must be done in accordance with both local and national electrical code.
WARNING: The Series 35-60 and 35-61 use voltages of shock hazard potential. Wiring and initial operation must be done by a qualified service technician.

| CONNECTION LIST - 35-60 EDGE CONNECT MODELS | | |
|---|---------------------------------|-------|
| PWR | 24 VAC Power | PIN 1 |
| NC | Alarm (normally closed contact) | PIN 3 |
| VALVE | Valve Power (output) | PIN 4 |
| SENSE | Remote Flame Sensor | PIN 5 |
| GROUND | System Power | PIN 6 |

TROUBLESHOOTING GUIDE

| SYMPTOM | RECOMMENDED ACTIONS |
|--|--|
| 1. Dead | A. Miswired B. Transformer bad C. Fuse/Circuit breaker bad D. Bad control (check LED for steady on) |
| 2. Thermostat on- no spark | A. Miswired B. Bad thermostat C. No voltage at terminal TH |
| 3. Valve on, no spark | A. Shorted electrode B. Open HV cable C. Miswired D. Bad control |
| 4. Spark on, no valve | A. Valve coil open B. Open valve wire C. Bad control (check voltage between V1 & V2) |
| 5. Flame OK during TFI, no flame sense after TFI | A. Bad electrode B. Bad S1 or HV wire C. Poor ground at burner. |

FLAME SENSOR CURRENT CHECK

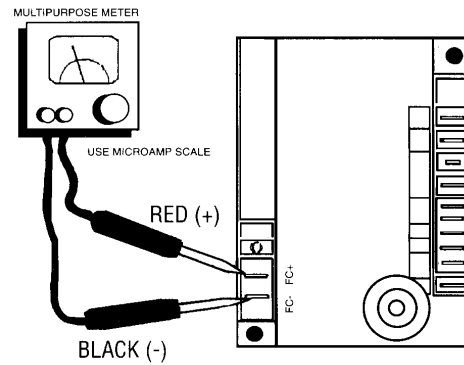

SERVICE CHECKS

Flame current is the current which passes through the flame from the sensor to ground. The minimum flame current necessary to keep the system from lockout is .7 microamps. To measure flame current, connect a DC microammeter to the FC-FC+ terminals per figure. Meter should read .7 uA or higher. If the meter reads below "0" on scale, meter leads are reversed. Disconnect power and reconnect meter leads for proper polarity.

DIMENSIONS - EDGE CONNECT MODELS

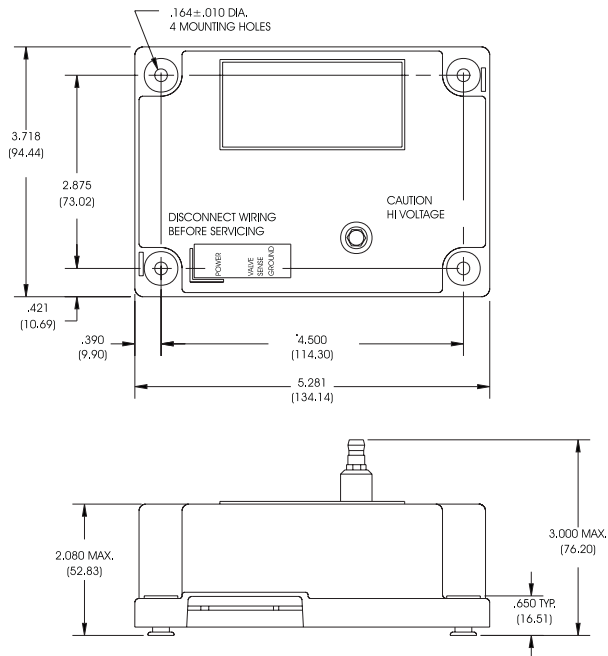

DIMENSIONS - QUICK CONNECT MODELS

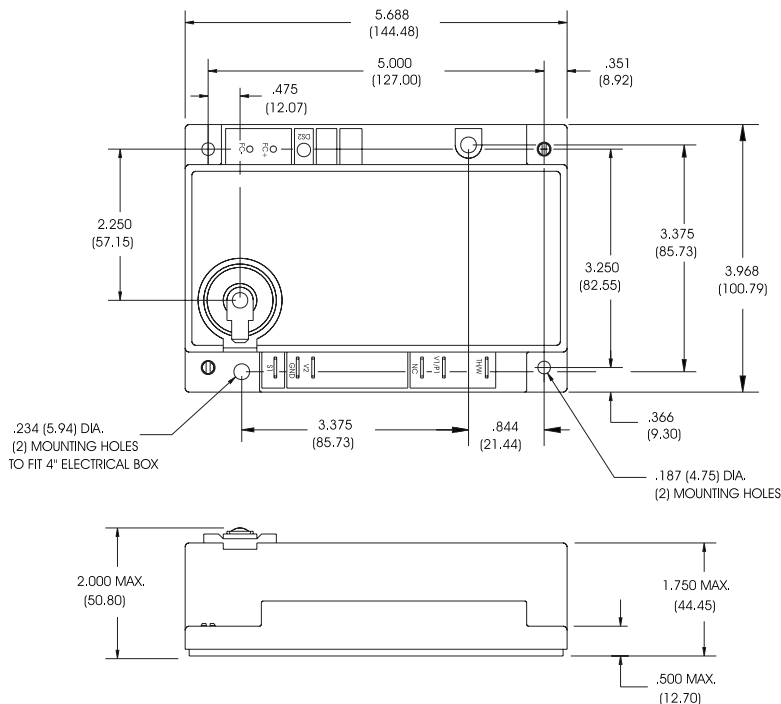

400 MAIN STREET, ASHLAND, MA 01721
TEL: (508) 881-2000
FAX: (508) 881-6729
www.fenwalcontrols.com

These instructions do not purport to cover all the details or variations in the equipment described, nor do they provide for every possible contingency to be met in connection with installation, operation and maintenance. All specifications are subject to change without notice. Should further information be desired or should particular problems arise which are not covered sufficiently for the purchaser's purposes, the matter should be referred to KIDDE-FENWAL, Inc., Ashland, Massachusetts.