

Flexible Averaging Temp Sensor

CE

Model TE-707

RoHS



- Two probe construction options - plenum rated cable or metallic armored cable.
- Sensor nodes are moisture sealed with a patented process to handle condensation and contaminants.
- An aluminum bracket is crimped over the sensing modules to stress relief the assembly to withstand installation and operational physical abuse.
- Available with polycarb, galvanized steel or NEMA-4 / IP-65 powder coated steel enclosure to cover all applications.
- More than 16 types of interchangeable NTC thermistors, precision platinum, nickel or balco RTDs are available for universal compatibility.

TE-707 flexible averaging temperature sensors offer many benefits over rigid tubular sensors. Rigid sensors have to be uncoiled and then bent into position using a tube bender. If kinked, moisture will enter, condense and cause intermittent shorts. Flexible sensors are easy to install and are moisture sealed. Just clip or tie directly to the heat exchanger, coil or duct. Unlike tube averaging sensors, the sensing nodes in flexible cable are clearly identified and can be positioned to correctly average the temperature across the face of the coil or duct. The sensing elements in rigid tubular averaging sensors are not in contact with the tube and may have an air gap resulting in slow response time. The sensing nodes in flexible averaging sensors have a thin protective sheath directly in contact to the sensing element resulting in an extremely fast response time thus eliminating false freeze stat trips.

MAMAC SYSTEMS®

8189 Century Boulevard • Minneapolis, MN 55317-8002 • USA
800-843-5116 • 952-556-4900 • Fax 952-556-4997
sales@mamacsys.com • www.mamacsys.com

4200 Waterside Centre
Solihull Parkway
Birmingham • West Midlands
B37 7YN • United Kingdom
01384-271113 • Fax 01384-271114

1 Fullerton Road #02-01
One Fullerton
Singapore • 049213
65-31581826 • Fax 65-31581826

4 Armiger Court, Unit 2
Adelaide • S.A.
5088 • Australia
08-8395-4333 • Fax 08-8395-4433

675 Cochrane Drive
East Tower • 6th Floor
Toronto • Ontario
L3R 0B8 • Canada
905-474-9215 • Fax 905-474-0876

TE-707

Flexible Plenum Cable Duct Averaging Temp Sensor

The TE-707 Plenum Cable averaging temperature sensor incorporates four equally spaced sensor modules interconnected with a UL listed CL3P plenum rated cable. The sensor nodes are moisture sealed with epoxy encapsulation and protected by a polyolefin sheath to provide a rugged and reliable assembly.

Sensor modules are mechanically protected against flex and physical abuse with an aluminum clip which is crimped across the module to form a bridge to stress relieve the assembly. The averaging temp sensor incorporates four even spaced sensor modules over 6, 12 or 24 ft / 1.8, 3.6, or 7.2 meter lengths to handle any size duct or plenum.

Available with polycarb, galvanized steel or NEMA-4 / IP-65 powder coated steel enclosure to cover all applications.

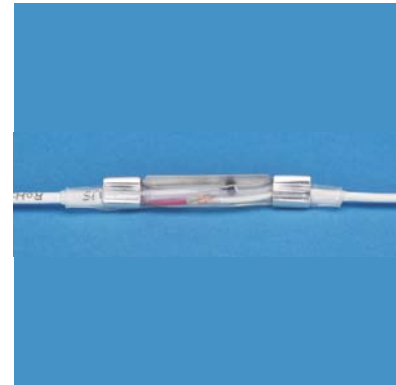

Flexible Armored Cable Duct Averaging Temp Sensor

The TE-707 Armored Cable averaging temperature sensors incorporate the same plenum cable sensors except the assembly is protected with a woven metallic sheath to enhance ruggedness and to improve thermal conductivity across the four sensing modules. 384 monolithic 32 gauge tin plated copper fibers are woven into a continuous metallic sheath over the plenum rated, moisture sealed, averaging cable temperature sensor.

The metallic woven sheath is secured to the cable sensor ends and all installation and operational stress or pull force is absorbed by the 384 copper fibers resulting in a very rugged flexible sensor. Tin plated copper fibers provide excellent thermal conductivity across the length of the flexible sensor and bridging clips across the sensing modules support the assembly against flex and mechanical abuse. The averaging temp sensor incorporates four even spaced sensor modules over 6, 12 or 24 ft / 1.8, 3.6, or 7.2 meter lengths.



TE-707

SPECIFICATIONS:

Platinum RTD sensors:	+/- 0.1% @ 0 C, Alpha : 385 per DIN 43760
Nickel RTD sensors: (#2)	+/- 0.5 C @ 0 C, 5000 PPM/K T.C.R.
Nickel RTD sensors: (#4)	+/- 0.5 F @ 70 F / 21.1 C, 6000 PPM/K T.C.R.
Balco RTD sensors:	+/- 0.5 F @ 70 F / 21.1 C, 4300 PPM/K T.C.R.
Operating Temp:	-40 F - 200 F (-40 C - 93 C)
Thermistor sensors:	+/- 0.2 C interchangeability @ 77 F / 25 C
Plastic Enclosure:	Polycarbonate 30% glass filled, rated UL 94V-5-0
Steel NEMA-1 / IP-30:	18 Ga. Galvanized Steel
Steel NEMA-4 / IP-65:	18 Ga. Cold Rolled Steel, Baked on Enamel
Warranty:	Five Years (Lifetime on Moisture Migration)
EMC Conformance:	EN 55022, 55024, 61000-3-3, 61000-4-2, 3, 4, 5, 6 & 11
RoHS Compliant	

Covered under: U.S. PATENT NO. 6592254, 7465087

ORDERING INFORMATION: TE-707-

Installation	Sensor*	Probe Length	Probe Type
A Polycarb Plastic Enclosure	1 100 ohm Platinum RTD	A 6 feet / 1.8 m	1 Plenum cable
B Galvanized Steel Enclosure	2 1,000 ohm Nickel RTD (5000 PPM)	B 12 feet / 3.6 m	2 Armored cable
C Painted Steel Enclosure	3 1,000 ohm Platinum RTD	C 24 feet / 7.2 m	
NEMA-1/IP-30	4 1,000 ohm Nickel RTD (6000 PPM)		
	5 1,000 ohm Balco RTD		
	7 10,000 ohm NTC thermistor (Type III)		
	8 10,000 ohm NTC thermistor (Carel)		
	10 3,000 ohm NTC thermistor		
	12 10,000 ohm NTC thermistor (Type II)		
	13 5,000 ohm NTC thermistor		
	14 1,035 ohm Silicon PTC		
	15 100,000 ohm NTC thermistor		
	16 10,000 ohm NTC thermistor (Eliwell)		
	17 20,000 ohm NTC thermistor		
	18 2,252 ohm NTC thermistor		
	21 1,800 ohm NTC thermistor		

Example: TE-707-B-10-B-1: Duct averaging sensor, 12 feet flexible plenum cable, 3000 ohm thermistor, NEMA-1 enclosure.

* For sensor compatibility, please refer to TI.700-10.

** For a complete Resistance vs. Temperature tables, please refer to TI.700-11.

TE-707

TE-707-A

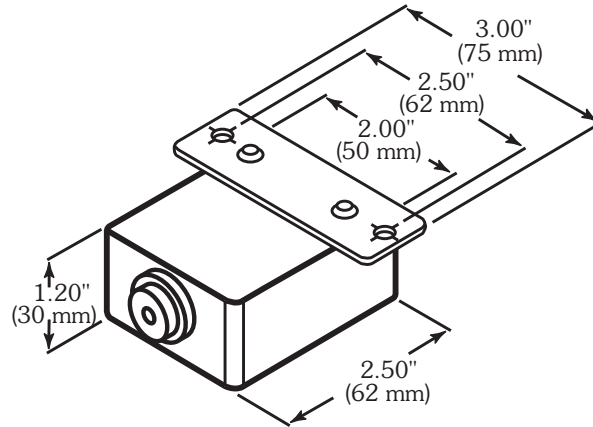

TE-707-B/C

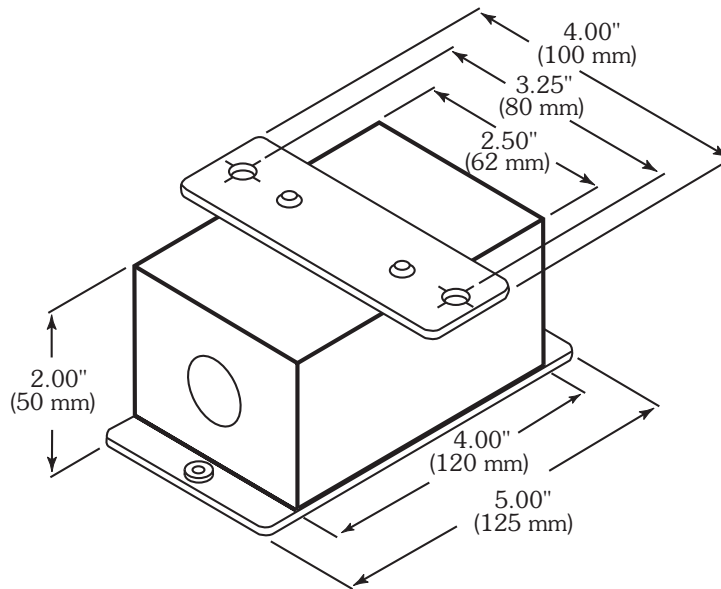

TE-707



MAMAC Systems is the leading global manufacturer of sensors, transducers, control peripherals and web browser based IP appliances. MAMAC products are used for HVAC and environmental controls, remote monitoring, alarming, energy metering and industrial automation.

All MAMAC products are manufactured in the USA.

WARRANTY: MAMAC Systems, Inc. and its subsidiaries (hereinafter referred to as MAMAC Systems) warrants its products to be free of defects in material and workmanship for a period of five (5) years from date of shipment. If a unit is malfunctioning, it must be returned to the factory for evaluation. A return authorization number (RMA) will be issued by the customer service department and this number must be written or prominently displayed on the shipping boxes and all related documents. The defective part should be shipped freight pre-paid to the factory. Upon examination by MAMAC Systems, if the unit is found to be defective, it will be repaired or replaced at no charge to the customer. However, this warranty is void if the unit shows evidence of being tampered with, damaged during installation, misapplied, misused, or used in any other operating condition outside of the unit's published specifications.

MAMAC Systems makes no other warranties or representations of any kind whatsoever, expressed or implied, except that of title. All implied warranties including any warranty of merchantability and fitness for a particular purpose are hereby disclaimed. User is responsible to determine suitability for intended use.

LIMITATIONS OF LIABILITY: The remedies of buyer set forth herein are exclusive and the total liability of MAMAC Systems with respect to this order, whether based on contract, warranty, negligence, indemnification, strict liability or otherwise, shall not exceed the purchase price of the product upon which liability is based. **In no event shall MAMAC Systems be liable for consequential, incidental or special damages.** MAMAC Systems reserves the right to change any specifications without notice to improve performance, reliability, or function of our products.

Every precaution for accuracy has been taken in the preparation of this manual, however, MAMAC Systems neither assumes responsibility for any omissions or errors that may appear nor assumes liability for any damages that result from the use of the product in accordance with the information contained in the manual.

MAMAC SYSTEMS[®]

8189 Century Boulevard • Minneapolis, MN 55317-8002 • USA
800-843-5116 • 952-556-4900 • Fax 952-556-4997
sales@mamacsys.com • www.mamacsys.com

4200 Waterside Centre
Solihull Parkway
Birmingham • West Midlands
B37 7YN • United Kingdom
01384-271113 • Fax 01384-271114

1 Fullerton Road #02-01
One Fullerton
Singapore • 049213
65-31581826 • Fax 65-31581826

4 Armiger Court, Unit 2
Adelaide • S.A.
5088 • Australia
08-8395-4333 • Fax 08-8395-4433

675 Cochrane Drive
East Tower • 6th Floor
Toronto • Ontario
L3R 0B8 • Canada
905-474-9215 • Fax 905-474-0876